

B-2025-04-07





2024

2.1

2024

CO <sub>2</sub>	723.32	723.32
CO <sub>2</sub>	/	/
CO <sub>2</sub>	/	/
CO <sub>2</sub>	8707.78	8707.78
CO <sub>2</sub>	10720.67	10720.67
	CO <sub>2</sub>	723.32
	CO <sub>2</sub>	20152

2.2

C2661

2024

2024

2023

( CO <sub>2</sub> )	19221	20152	4.84%
	217364	228301	5.03%

	( CO <sub>2</sub> / )	0.0884	0.0883	-0.18%
4.84%	2024	2024	5.03%	
	0.18%	2024		5.03%
				2025.4.02
				2025.4.08
				2025.4.10

1.1	.....	1
1.2	.....	1
1.3	.....	2
2.1	.....	4
2.2	.....	4
2.3	.....	4
2.4	.....	5
3.1	.....	6
3.1.1	.....	6
3.1.2	.....	7
3.1.3	.....	8
3.1.4	.....	23
3.2	.....	29
3.2.1	.....	29
3.2.2	.....	30
3.3	.....	31
3.4	.....	34
3.4.1	.....	34
3.4.2	.....	38
3.4.3	.....	41
3.4.4	.....	42
3.5	.....	43
3.6	.....	43
4.1	.....	44

4.2	.....	44
4.2.1	.....	44
4.2.2	.....	44
4.3	.....	45
4.4	.....	45
1	.....	46
2	.....	47

2024

(1)

(2)

2024

CO<sub>2</sub>

CO<sub>2</sub>

CO<sub>2</sub>

CO<sub>2</sub>

1

2

3

4

-

17

-

-

-

-

GB/T 2589-2008

-

GB17167-2006

-

-

2024

-

2024

1		1 2 3
2		1 2

2025 03 17 2025  
03 28 2024

2025 03 30

2025 03 30			

1

2025 04 02

2025 04

08

2025

04 10

1

-

-

-

C2661

-

91330100MA2H12WA2A

-

-

-

1818

-

34565

-

2019 12 03

-

2

2024

		138722	
		22196	
		228301	
		8394.23	

3

3-1

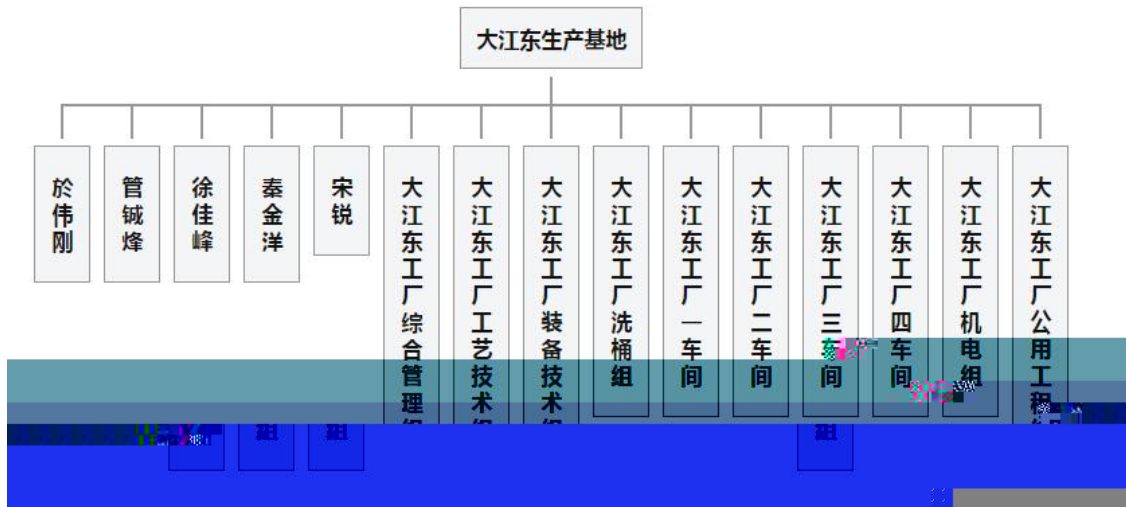

GB17167

1

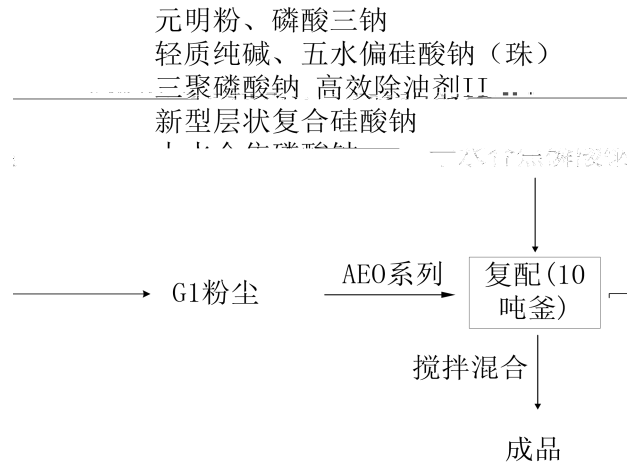

(  
II + (AEO  
)  
)

15 20

2

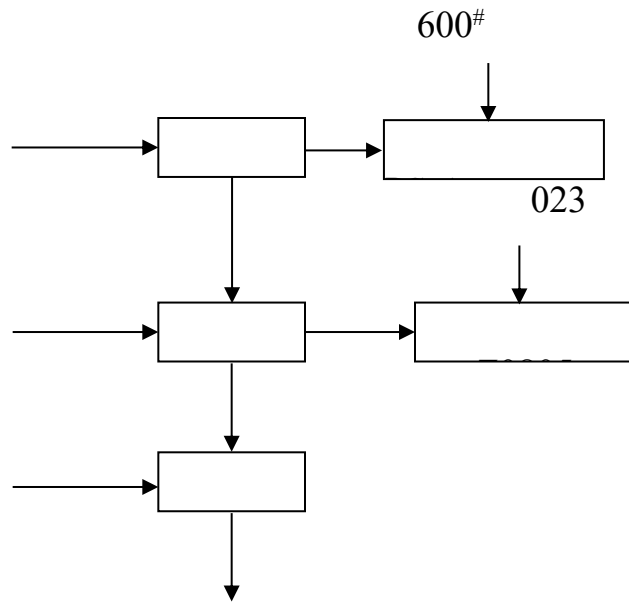

PS-A

600K

PS-A

023

Z0805

CDT

3

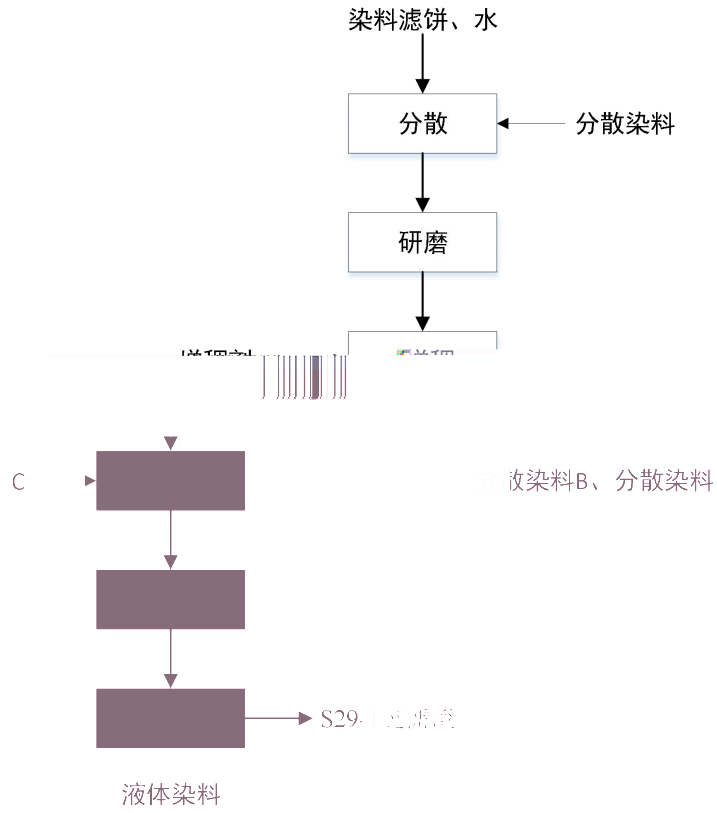

0.5

1.5  
6 10  
6 10  
3

3

3

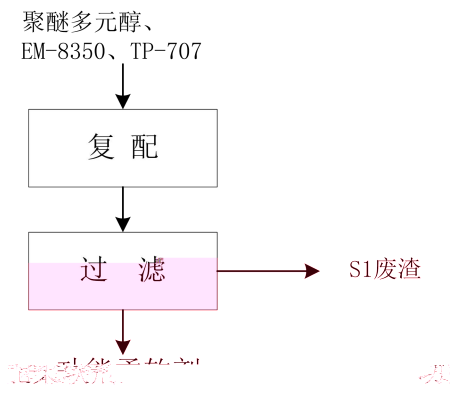

TP-707	EM-8350	
	40 50	1 2

4

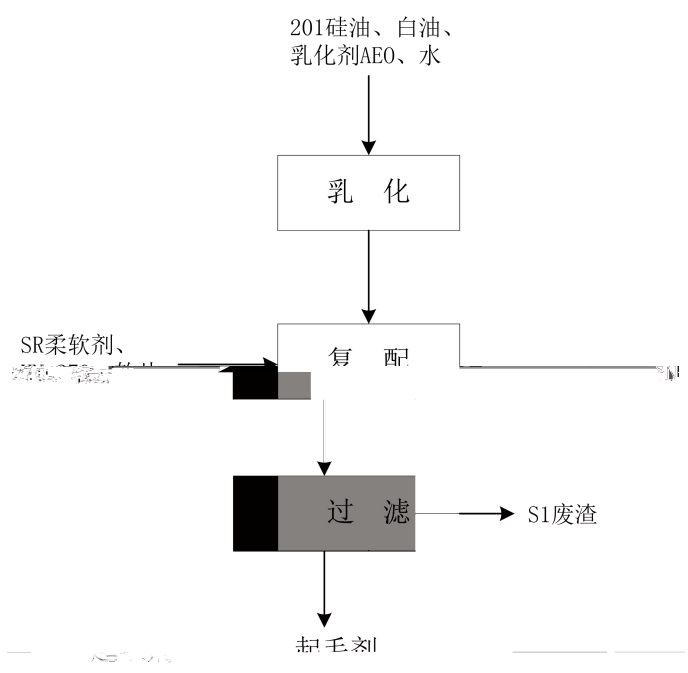

201	AEO
-----	-----

	1	2		0.5
SR		YN-270	40	50
				1
				2

5

去离子水、酶浓缩液、  
表面活性剂、尿素、杀菌剂

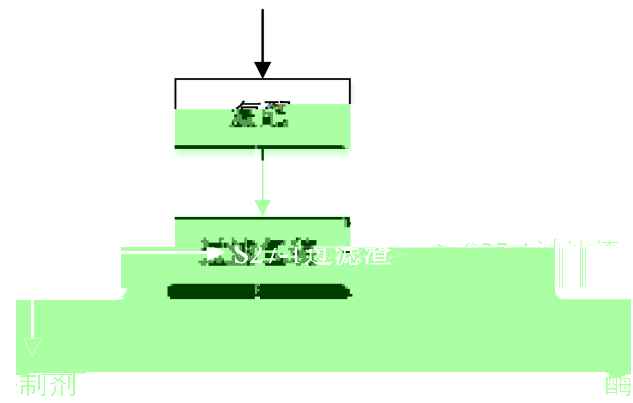

1

6

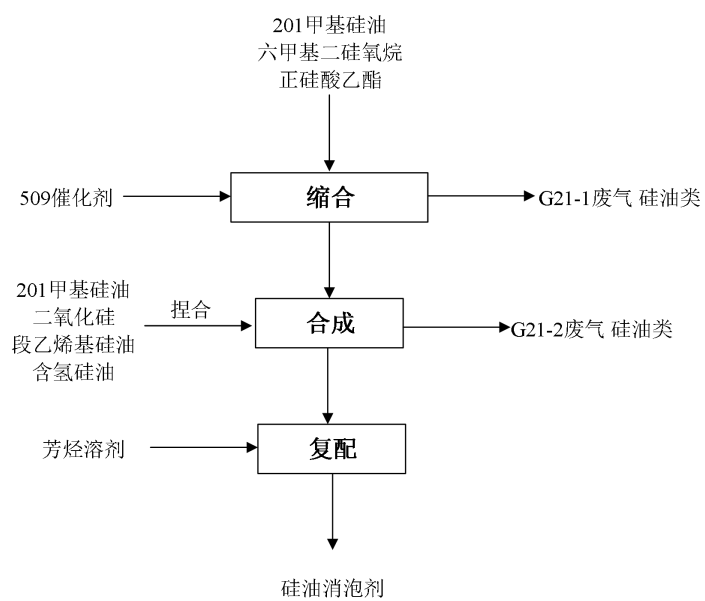

509	201	115	1
70		180	3

7 6501

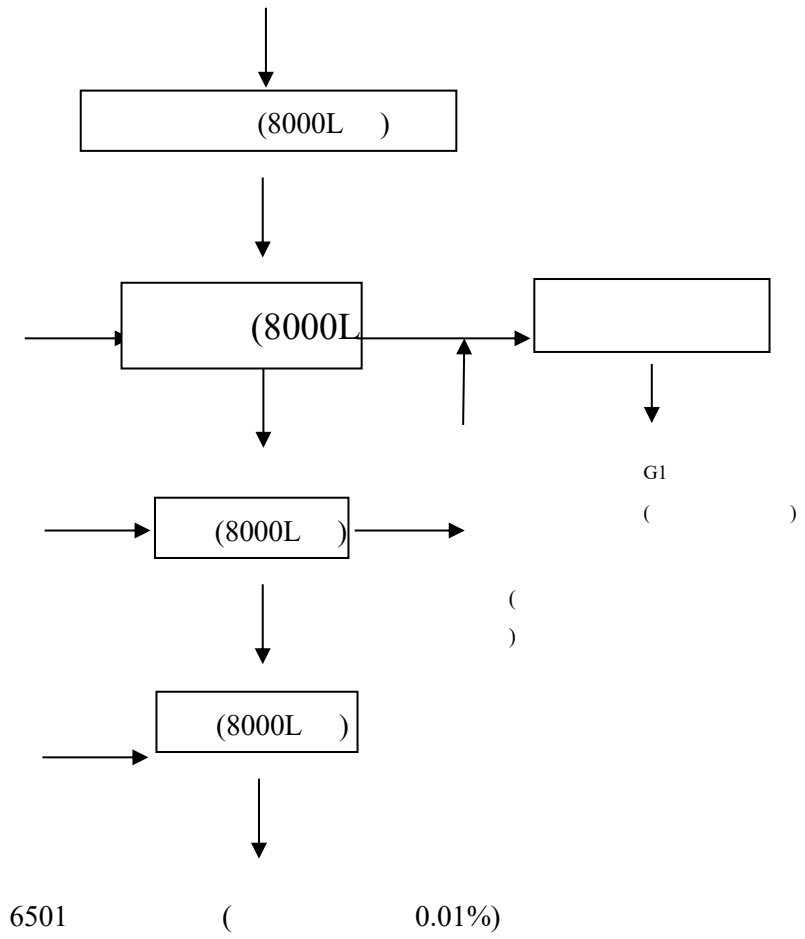

30

( )

0.09 a

70 90

3

60

( ) H 30-60  
 ( )  
 6501

30-60

8

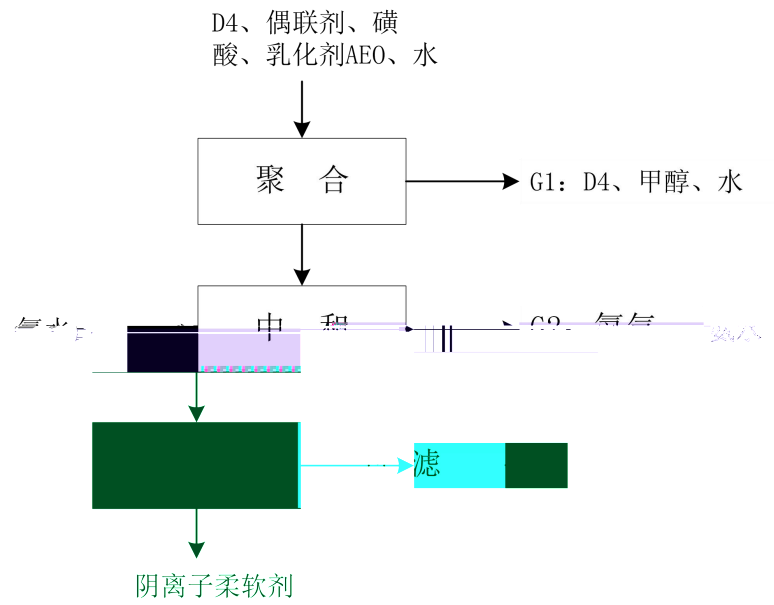

D4		AEO		
70	80	3	4	D4
	40	50		0.5



7 KOH 1 2 KOH ( )  
-15 )  
+

130 135 4 ( )

95%

1 70 80 A  
60

A  
0.5 1 2

2 3% A A

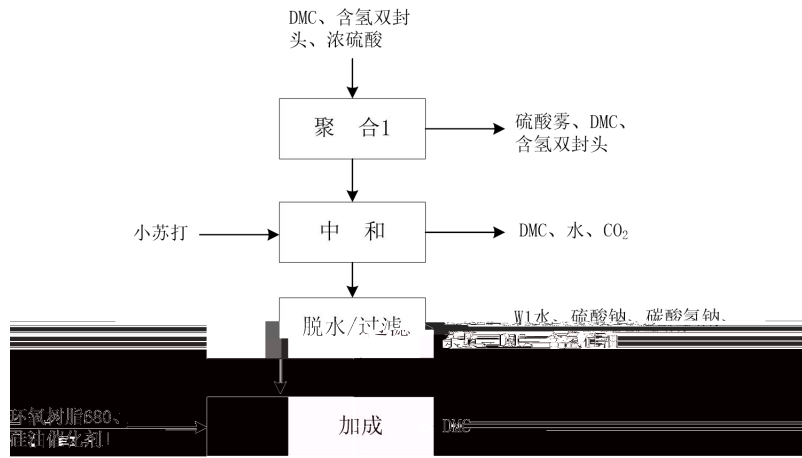

1  
DMC +



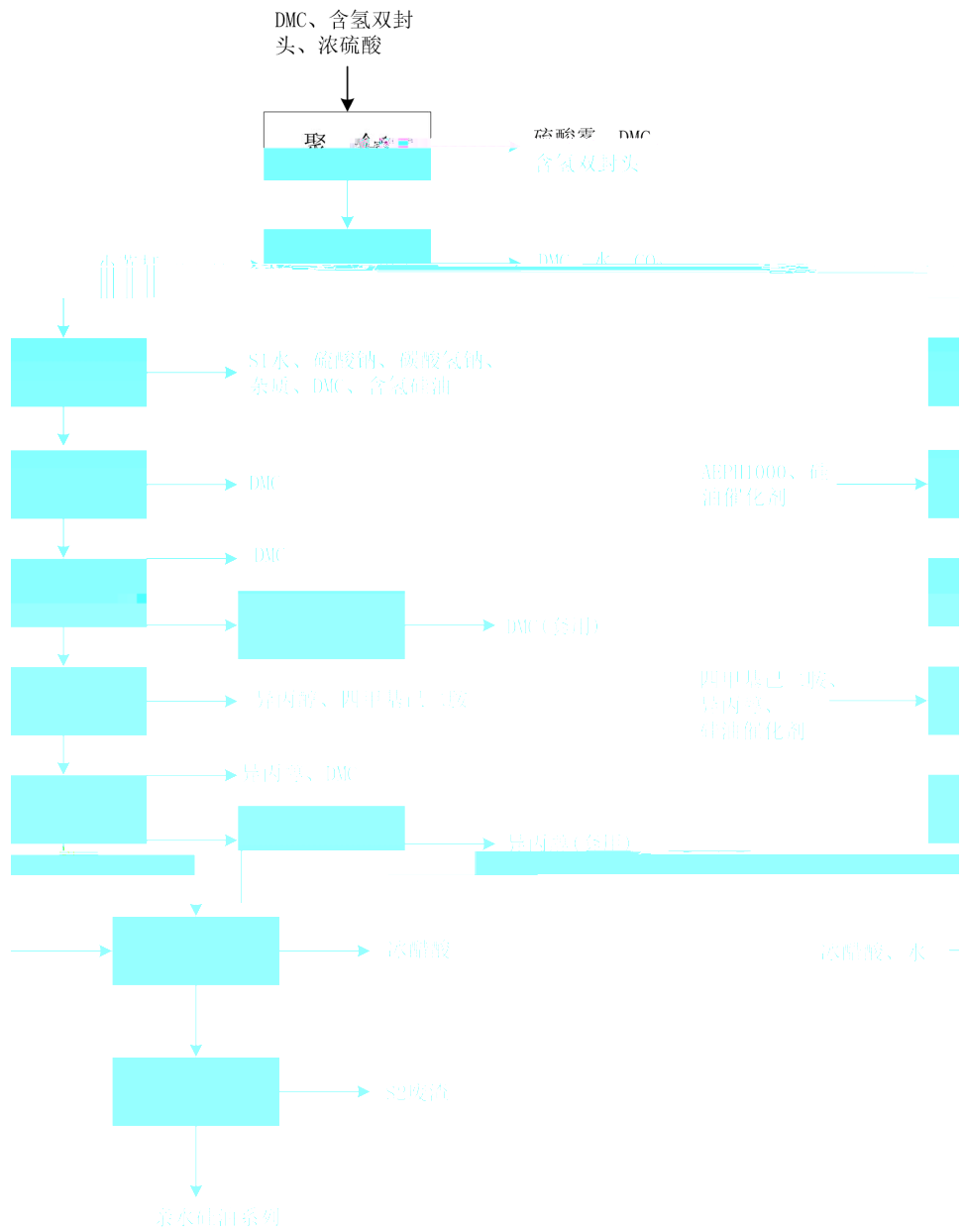

1  
DMC +

30 40 3 DMC

30 70 80 2 DMC 1 DMC

AEPH 1000

80 90 3

0.098MPa

( )

0.098MPa

130

4

50

( )

2

14

EXAEO系列、AEO系列  
 SOFTANOL-90、乙二醇丁醚  
 杀菌剂WL-20、平平加O  
 尿素、乙醇、四氯乙烯、水

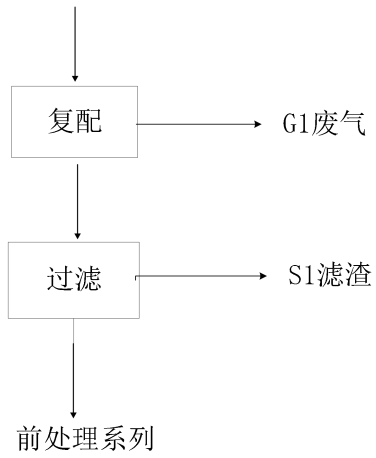

	EXAEO	AEO	SOFTANOL-90
O	50	55	2.5 3
( )		40	1
	200		

## 3-2

				W			
1		LGS-20/8G	1	110K		2017-08	
2		LGS-20/8G	1	110K		2017-08	
3		QGDV160W-8	1	160K		2020-12	
4		LS20MMZA	1	250K		2017-09	
5		LS20MMZA	1	250K		2017-09	
6		YS16MNHZA	1	110K		2017-09	
7		XBD8/80-QW	3	110K		2017-07	
8		XBD12/60-150L-KQ	2	132K		2021-05	
9		3LP130-55/5	1	110		2019-10	
10		3LP110-45/5	1	75		2019-10	
11			1	55		2018-10	
12		HF-421B	1	55 W		2020-11	
13			3	11 W		2019-09	
14			1	22 W		2019-09	
15			2	75 W		2019-09	
16			6	7.5 W		2019-09	
17			4	45 W		2019-06	
18			2	75 W		2019-06	
19			2	30 W		2019-06	

20			10	22 W		2019-06	
21			3	37 W		2019-06	
22			8	15 W		2019-06	
23			5	11 W		2019-06	
24			5	11 W		2019-06	
25			8	75 W		2019-06	
26			2	26 W		2019-06	
27			1	30 W		2019-06	
28			2	22 W		2019-06	
39			2	22 W		2019-06	
30			5	18.5 W		2019-06	
31			4	55 W		2019-06	
32			8	15 W		2019-06	
33		DMX250M-2	3	55 W		2021-08	
34		GYB5000A-65-Q-N	3	90 W		2021-08	
35			1	37 W		2021-08	
36			12	30 W		2019-04	
37			24	22 W		2019-04	
38			10	37 W		2019-04	
39			5	22 W		2019-04	
40			3	15 W		2019-04	

41			2	18.5 W		2019-04	
42		ALB125/40	2	55 W		2017-07	
43		ALB125/40	1	55 W		2017-07	
44		ALB50/120	2	15 W		2017-07	
45		ALB125/26	3	18.5 W		2017-07	
46		ALB100/40	2	37 W		2017-10	
47		ALB100/40	2	37 W		2017-10	
48		ALB100/40	1	37 W		2017-07	
49		ALB125/40	1	55 W		2017-07	
50		ALB150/40	1	75 W		2017-07	
51		ALB150/40	1	75 W		2017-07	
52		KQW125	1	37 W		2017-07	
53		KQW125	2	37 W		2017-07	
54		CDLF80/40	1	30 W		2019-10	
55			2	22 W		2019-10	
56			1	45 W		2019-10	
57			1	45 W		2019-10	
58		BLD18.5-5-13	2	18.5 W		2020-05	
59		YB300J-60	1	37 W		2019-10	
60		HDSR-150A	2	30 W		2017-10	
61		SF75	1	75 W		2020-10	
62		XAAGF300/1500-4	1	37 W		2020-08	
63			9	5.5 W		2017-10	

64			31	7.5 W		2017-10	
65			12	11 W		2017-10	
66			4	15 W		2017-10	
67			4	22KW		2019-04	
68			30	7.5 W		2019-04	
69			27	11 W		2019-04	
70			2	7.5 W		2019-04	
71			9	15 W		2019-04	
72			2	18.5 W		2019-04	
73			4	22 W		2019-04	
74			7	15 W		2019-04	
75			6	11 W		2019-04	

		DSSD331	2		
		DSSD331	2		
		DSSD331	2		
		AGR96EL	0.5		
		AGR96EL	0.5		
		AGR96EL	0.5		
		AGR96EL	0.5		
		AGR96EL	0.5		
		AGR96EL	0.5		
		AGR96EL	0.5		
		AGR96EL	0.5		
		AGR96EL	0.5		
		AGR96EL	0.5		
		AGR96EL	0.5		
		DT862a	0.1		
		DT862a	0.1		
		DT862a	0.1		
		ZT-3000A	0.5		9
		ZT-3000A	0.5		4

1818

2024

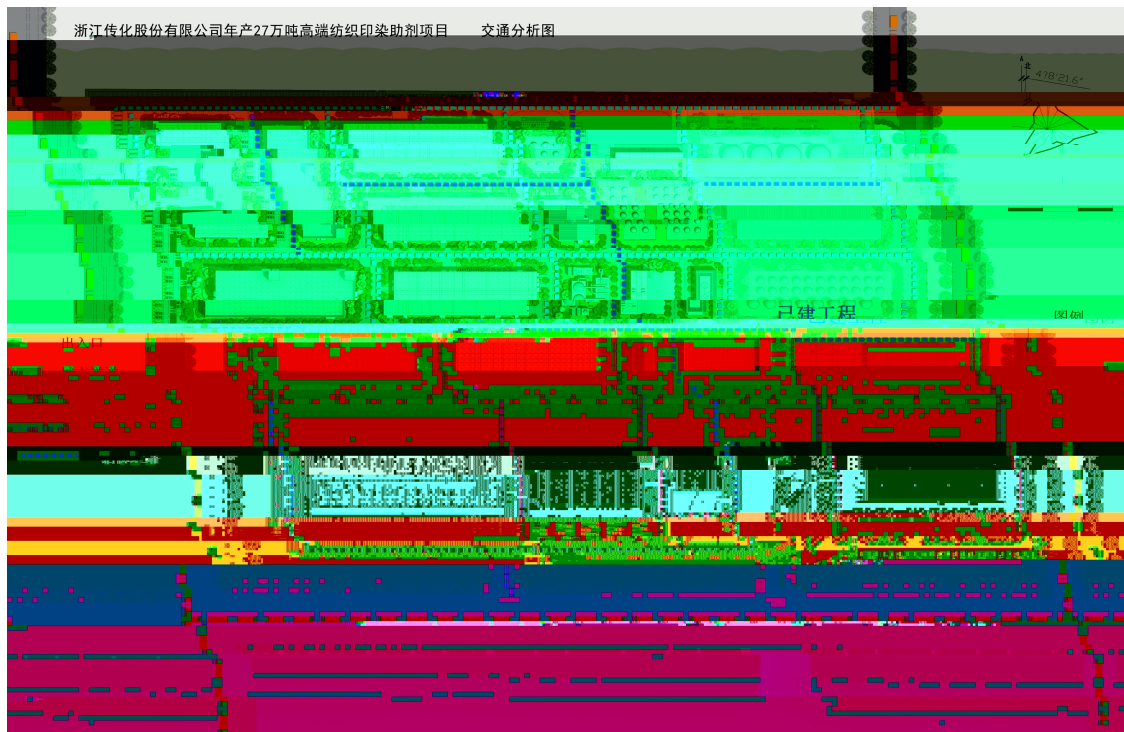



CO<sub>2</sub>

CO<sub>2</sub>

/

RTO

$$E = E_{\text{燃烧}} + E_{\text{原材料}} + E_{\text{过程}} + E_{\text{电}} + E_{\text{热}}$$

E

CO<sub>2</sub>

E

CO<sub>2</sub>

E

CO<sub>2</sub>

E

CO<sub>2</sub>

E

CO<sub>2</sub>

E

CO<sub>2</sub>

$$E_{\text{CO}_2\text{燃烧}} = \sum_i \left( AD_i \times CC_i \times OF_i \times \frac{44}{12} \right)$$

AD

$N^3$

CC

/

/  $N^3$

OF

%

CC=NCV EF

NCV

GJ/

GJ/  $N^3$

EF

/GJ

E =AD EF

E

CO<sub>2</sub>

CO<sub>2</sub>

AD

MW

EF

CO<sub>2</sub>

CO<sub>2</sub>/MW

E =AD EF

E

CO<sub>2</sub>

CO<sub>2</sub>

AD

GJ

EF

CO<sub>2</sub>

CO<sub>2</sub>/GJ

		33.45326		33.45326
	1			
	2			
		33.45326		33.45326
		/		
	1			2024
		33.45326 <sup>3</sup>		
	2			2024
		33.45326 <sup>3</sup>		



		96154.37		97460.604
	GJ			
	$AD = Ma * (E - 83.74) * 10^{-3}$			
	AD		GJ	
	Ma			
	E			
	J/			
		165	0.423MPa	EQ3.0
		2783.74 J/		
	1			
	2			

		36096.52	36096.52
		/	0%
1	36096.52	97460.604GJ	2024
2		2024	36096.52 0%
	NC1		

		GJ	GJ
	36096.52	97460.604	36096.52 96154.37

		389.31		389.31
	GJ/			

		0.0153		0.0153
	C/GJ			

		98		98
	%			

		0.5366		0.5366
	CO <sub>2</sub> /MW			
	2022			
	2022			

		0.11		0.11
	CO <sub>2</sub> /GJ			

--	--

2024

2024

	A	B	C	D	$E = \frac{A * B * C * D}{100 * 44 / 12}$
	33.45326	389.31	0.0153	98	723.32

16227.700	0.5366	8707.78

97460.604	0.11	10720.67
-----------	------	----------

-

-

-

-

-

2024

2024

CO <sub>2</sub>	723.32	723.32
CO <sub>2</sub>	/	/
CO <sub>2</sub>	/	/
CO <sub>2</sub>	8707.78	8707.78
CO <sub>2</sub>	10720.67	10720.67
	CO <sub>2</sub>	723.32
	CO <sub>2</sub>	20152

C2661

2024

2024

2023

	( CO <sub>2</sub> )	19221	20152	4.84%
		217364	228301	5.03%
	( CO <sub>2</sub> / )	0.0884	0.0883	-0.18%

2024

4.84% 2024

5.03%

0.18%

2024

5.03%

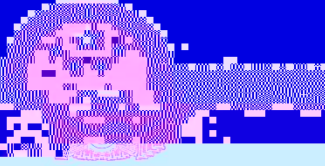

1	
2	
3	



营业执照

(副本)

统一社会信用代码  
91330100MA2H12WA2A (1/1)

  
 扫描二维码  
 下载国家企业信用信息公示系统APP  
 市场主体信息一目了然

名称	浙江传化功能新材料有限公司	注册资本	叁亿肆仟伍佰陆拾伍万元整
类型	有限责任公司(自然人投资或控股的法人独资)	成立日期	2019年12月03日
法定代表人	傅幼林	营业期限	2019年12月03日至长期



国家企业信用信息公示系统网址: <http://www.gsxt.gov.cn>

市场主体应当于每年1月1日至6月30日通过  
 国家信用信息公示系统报送公示年度报告。

国家市场监督管理总局监制

